

A tradition of
grand performance
deserves an encore.

Introducing the Mooney Encore.

The newest Mooney is coming. Fast.

Joining our proud line of high-performance singles in mid-year 1997 is the new 220 hp turbo-intercooled Encore – combining the classic K-model fuselage and the Continental TSIO-360-SB engine.

Outfitted with new-generation propeller technology, the Encore has a projected cruise speed of 200-plus kts and an IFR range in excess of 800 nm. Maximum gross weight has been significantly improved over previous Mooney models in the same class, providing an additional 200 pounds of useful load.

The airframe is built in the Mooney tradition with a laminar-flow wing built tip-to-tip in one strong, single piece. The cabin is cocooned in a protective roll-bar type frame of chrome-moly steel tubing. Redundant systems provide enhanced safety and reliability as well.

Call today about our new Encore. You'll enjoy the performance.

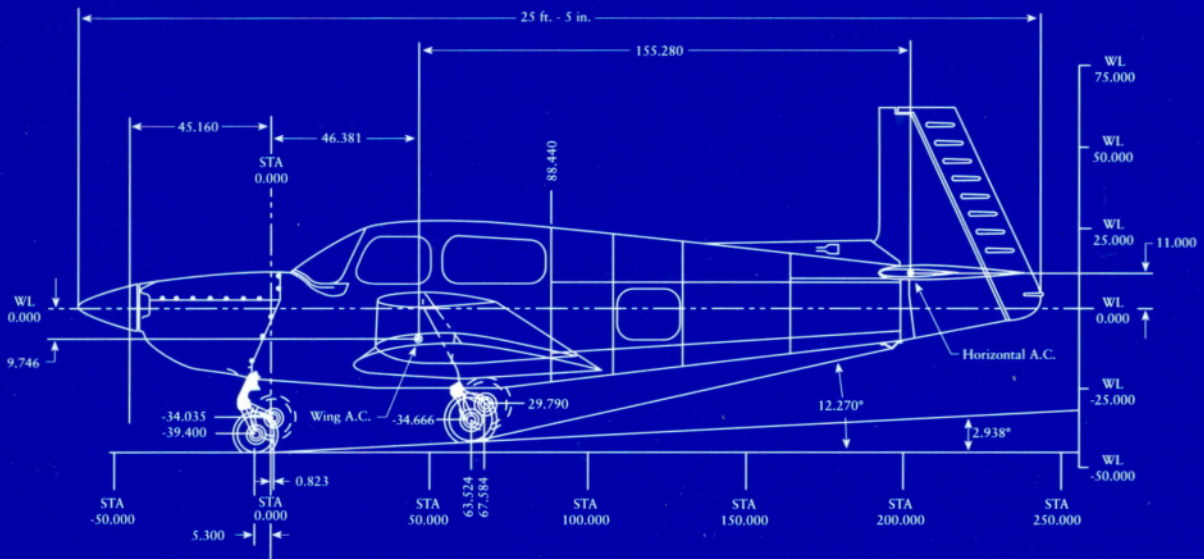
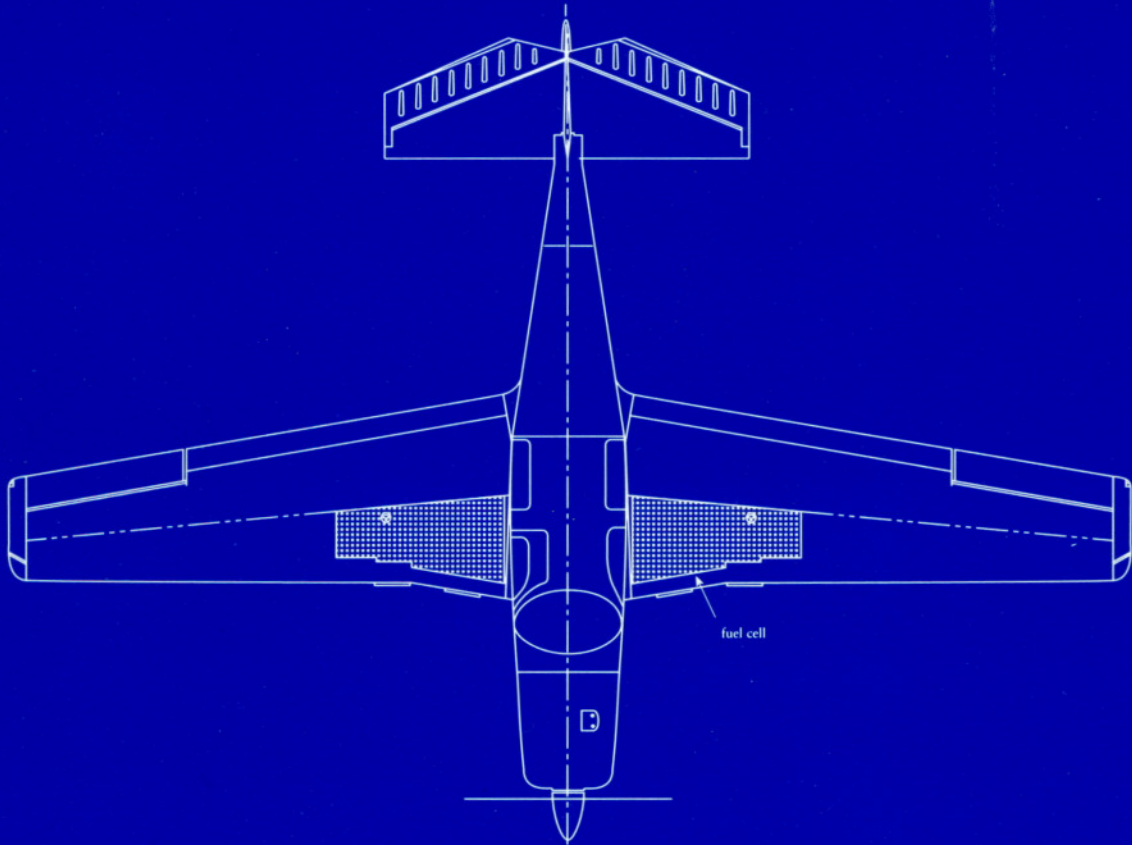
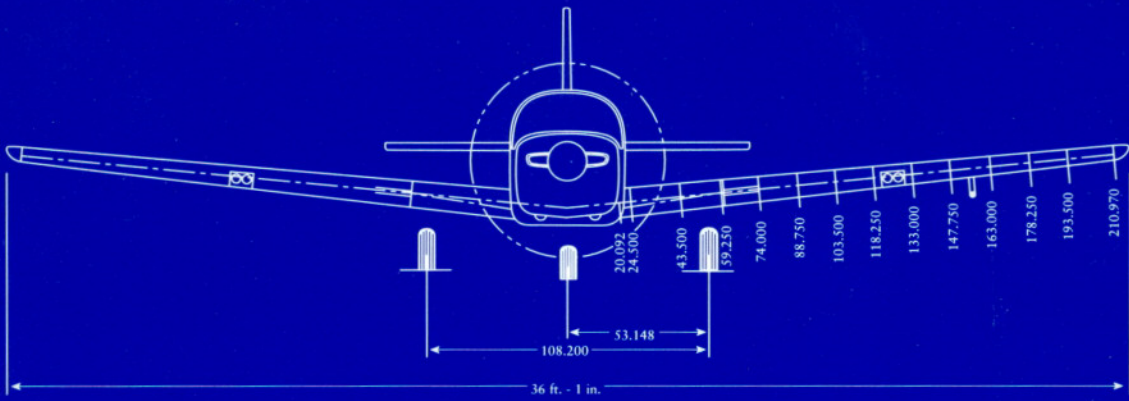

Projected Performance Data*

Stall speed, landing configuration	60 KIAS
Never exceed speed	196 KIAS
Best rate of climb sea level	1,300 FPM
Best rate of climb 5,000 ft.	1,100 FPM
Cruise speed (PWR/SPEED/ALT.)	MCP, 210 KTAS, FL250 MCP, 213 KTAS, FL220 75%, 197 KTAS, FL220
Maximum range (PILOT, 2 PAX FULL FUEL)	1,100 NM
Maximum duration	6 hrs.

Exterior Dimensions

Span	36 ft. 1 in.
Height	8 ft. 4 in.
Length	25 ft. 5 in.

Areas

Wing (Sw)	174.786 sq. ft.
Flap (Sf)	17.5 sq. ft.
Ailerons (Sa)	11.5 sq. ft.
Horizontal (Sh)	34.42 sq. ft.
Elevator (Se)	13.00 sq. ft.
Vertical (Sv)	7.84 sq. ft.
Rudder (Sr)	6.23 sq. ft.
Dorsal fin (Sd)	1.19 sq. ft.

Weights

Empty	2000 lbs.
Gross	3100 lbs.
Useful load	1100 lbs.
Payload (typically equipped)	650 lbs.
Wing loading	17.7 lbs./sq. ft.
Power loading	14.1 lbs./hp.
CG range	sta. 41 to 50.1

Cabin Dimensions

Width	43.50 in.
Height	44.50 in.
Length	114.0 in.
Access door	17.0 x 21.0 in.
Baggage volume	13.5 ft. ³

Powerplant Data

Engine	TCM TSIO-360-SB
SL hp. rating	220
Propeller mfr.	*
Propeller dia.	74.0 in.
Engine oil capacity	8.0 qts.
Total fuel tank capacity	80 US gal., 78.6 usable

Landing Gear Data

Wheel track	9 ft. 02 in.
Wheel base	5 ft. 11.56 in.
Main tires	6.00-6 6 ply
Nose tire	5.00-5 6 ply

* All specifications and performance are preliminary and subject to final certification.